



8510 Low Voltage Compressor,  
(For Use with On-Board<sup>®</sup> High-Vacuum  
Pumps)  
Installation, Operation and Service  
Instructions

Information provided within this document is subject to change without notice, and although believed to be accurate, Brooks Automation assumes no responsibility for any errors, omissions, or inaccuracies.

AcuLigner™, Align™, AquaTran™, AutoTeach™, ATR™, AXM™, Basic Blue™, BiSymmetrik™, CenterSmart™, Cool Solutions™, Crate to Operate™, e-RMA™, e-Spares™, e-Volution™, FastRegen™, FIXLOAD™, FrogLeg™, InLigner™, InCooler™, Interface™, Jet Engine™, LowProfile™, M2 Nano™, Mini-Ion™, PASIV™, PowerPak™, PerformanceBlue™, PowerPak™, PowerTools™, QuadraFly™, Radius™, Radiant™, Radiant Express™, Reliance™, Reliance ATR™, RetroEase™, SCARA™, SmartPM™, SPOTLevel™, Synetics™, The New Pathway to Productivity™, Time Optimized Trajectory™, Time Optimal Trajectory™, Time Optimized Path™, TopCooler™, TopLigner™, Ultimate Blue™, VAC-407™, VacuTran™, Vacuum Quality Monitor™, VQM™, Vacuum Quality Index™, VQI™, and the Brooks logo are trademarks of Brooks Automation, Inc.

AcuTran®, AquaTrap®, Conductron®, Convector®, the Cool Solutions logo, Cryodyne®, Cryotiger®, Cryo-Torr®, Fusion®, GOLDLink®, Granville-Phillips®, Guardian®, GUTS®, Helix®, Jet®, Leapfrog®, MagnaTran®, MapTrak®, Marathon®, Marathon 2®, Marathon Express®, Micro-Ion®, MiniConvector®, On-Board®, Polycold®, Razor®, Simplicity Solutions®, the Simplicity Solutions logo, Stabil-Ion®, TrueBlue®, TurboPlus®, Vision®, Zaris®, and the Brooks Automation logo are registered U.S. trademarks of Brooks Automation, Inc.

All other trademarks are properties of their respective owners.

© 2013 Brooks Automation, Inc. All Rights Reserved. The information included in this manual is Proprietary Information of Brooks Automation and is provided for the use of Brooks Automation customers only and cannot be used for distribution, reproduction, or sale without the express written permission of Brooks Automation. This information may be incorporated into the user's documentation, however any changes made by the user to this information is the responsibility of the user.



**For Technical Support:**

Location	GUTS® Contact Number
North America	+1-800-FOR-GUTS (1-800-367-4887) +1-978-262-2900
Europe	+49-1804-CALL-GUTS (+49-1804-2255-4887)
Japan	+81-45-477-5980
China	+86-21-5131-7066
Taiwan	+886-3-5525225
Korea	+82-31-288-2500
Singapore	+65-6464-1481

Visit us online: [www.brooks.com](http://www.brooks.com)

January 11, 2013 Part Number 8040232 Revision AA

This technology is subject to United States export Administration Regulations and authorized to the destination only; diversion contrary to U.S. law is prohibited.

Printed in the U.S.A.

## Table of Contents

### Section 1 - Introduction

General .....	1-1
Installation, Operation and Service Instructions .....	1-1

### Section 2 - Inspection

Packaging of the System .....	2-1
The Compressor .....	2-1

### Section 3 - Installation

Compressor Installation .....	3-2
Preparing the Compressor .....	3-2
Assembling the Compressor Input-Power Cable .....	3-3
Electrical Preparation Of Compressor Control Module .....	3-5
Cooling Water: Preparation .....	3-5
Cooling Water: General Considerations .....	3-6
Cooling Water: Flow and Pressure Requirements .....	3-7
Cooling Water: Temperature Rise .....	3-10
Oil Circuit Stabilization .....	3-11
Connecting the Compressor to the Cryopump .....	3-11
Electrical Connection of Compressor .....	3-12
8510 Low-Voltage Compressor Electrical Phase Check and Automatic ON/OFF Control .....	3-13
System Phase Input Checkout Procedure .....	3-13
Automatic ON/OFF Control of the 8510 Low-Voltage Compressor Using the On-Board Setpoint Relays .....	3-14
Multipump Installation .....	3-14

### Section 4 - Maintenance Procedures

Scheduled Maintenance .....	4-1
Removing the Compressor Adsorber .....	4-2
Unscheduled Maintenance .....	4-4
Suggested Unscheduled Maintenance Equipment .....	4-4
Adding Helium Gas .....	4-4
Helium Circuit Decontamination .....	4-6
Cryopump Decontamination Procedures .....	4-6
Compressor Decontamination Procedures .....	4-8
Priming the Compressor Oil System .....	4-9

## Table of Contents (continued)

**Appendix A - Customer Support Information**

**Appendix B - Troubleshooting Procedures**

**Appendix C - Electrical Schematic for 8510 Low-Voltage Compressor**

**Appendix D - Electrical Control Module Components of the 8510 Low-Voltage Compressor**

**Appendix E - 8510 Low-Voltage Compressor Flow Diagram**

**Appendix F - Multiple Cryopump Installation with Single 8510 Low-Voltage Compressor**

## Figures

Figure 1-1: 8510 Low-Voltage Compressor: Front and Side Views . . . . .	1-2
Figure 1-2: 8510 Low-Voltage Compressor . . . . .	1-4
Figure 3-1: Block Diagram for 8510 Low-Voltage Compressor Installation . .	3-1
Figure 3-2: Removing Compressor Pump Shipping Supports . . . . .	3-2
Figure 3-3: Stripping Compressor Input-Power Cable Insulation . . . . .	3-3
Figure 3-4: Input Power Cable Receptacle Plug . . . . .	3-4
Figure 3-5: Wiring Diagram For Standard And Grounded Delta Configurations . . . . .	3-5
Figure 3-6: Preparing the 8510 Low-Voltage Compressor Control Module . . .	3-8
Figure 3-7: 8510 Compressor Cooling Water Flow And Pressure Requirements . . . . .	3-9
Figure 3-8: 8510 Compressor Water Discharge Temperature Increase ° F . . .	3-10
Figure 3-9: 8510 Low-Voltage Compressor Installation . . . . .	3-13
Figure 4-1: Disconnecting/Connecting the Adsorber Self-Sealing Couplings . .	4-2
Figure C-1: Electrical Schematic for 8510 Low-Voltage Compressor Drawing No. 8031350 Rev. F . . . . .	C-2

## Table of Contents (continued)

Figure D-1: Electrical Control Module Components of 8510 Low-Voltage Compressor .....	D-3
Figure E-1: Flow Diagram of 8510 Low-Voltage Compressor .....	E-1
Figure F-1: Typical Multiple Cryopump Installation with Single 8510 Low-Voltage Compressor .....	F-1

## Tables

Table 1-1: Compressor Dimensions P/N 8031315 .....	1-2
Table 1-2: Power Requirements (Steady-State Conditions) .....	1-2
Table 1-3: General Specification .....	1-3
Table 2-1: 8510 Shipping Carton Contents .....	2-1
Table 3-1: Compressor Control Module Specifications .....	3-8
Table 3-2: Electrical Leads .....	3-14
Table B-1: Compressor Troubleshooting Procedures .....	B-2
Table C-1: 8510 Fuses .....	C-1
Table C-2: Legend for Figure C-1 .....	C-3
Table D-1: Legend for Figure D-1 .....	D-2

*This Page Intentionally Left Blank*

# Section 1 - Introduction

## General

The manual provides instructions for installing, operating and servicing the 8510 Low-Voltage Compressor, P/N 8031315. If you are installing or operating an On-Board High-Vacuum System you should also have available the On-Board High-Vacuum Pump Manual that applies to your particular system:

- 8040215 On-Board 8 and 8F High-Vacuum Pumps
- 8040233 On-Board 10 and 400 High-Vacuum Pumps

The manuals for a system cover two basic components: the high-vacuum pump and the compressor. Each manual outlines the details necessary for installation, operation and service of that component. A manual is shipped with each system component (high-vacuum pump and compressor). When you purchase a system, you will receive the two manuals necessary for system installation, plus a loose-leaf binder with index tab separators, allowing you to compile a complete indexed system notebook.

## Installation, Operation and Service Instructions

Installation, Operation and Service Instructions for your 8510 Low-Voltage Compressor provide easily accessible information. All personnel with installation, operation, and service responsibilities should become familiar with the contents of these instructions to ensure high quality, safe, reliable performance.

Unit must be wired by an authorized electrician in accordance with the national electric code, ANSI/NFPA 70-1987, as well as the local codes.

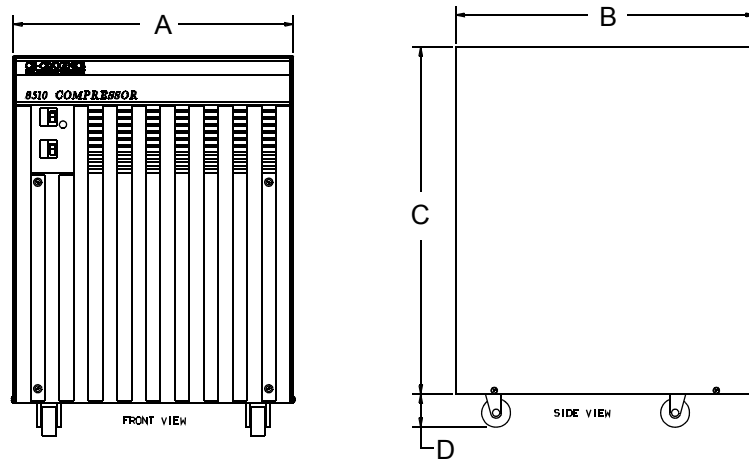

**Figure 1-1: 8510 Low-Voltage Compressor: Front and Side Views**

**Table 1-1: Compressor Dimensions P/N 8031315**

Location	Compressor Dimension Inches (mm)
A	19.40 max. (493 mm)
B	21.25 max. (540 mm)
C	24.12 max. (613 mm)
D	2.30 (58 mm)

**Table 1-2: Power Requirements (Steady-State Conditions)**

Compressor	Volts	Hz	Phase	Full Load Current (Amps)	Operating Voltage Range (Volts)	Maximum Phase Run Current (Amps)
8510, Part No. 8031315	208/230	60	3	17	198-250	24
	200	50	3	15	190-230	23



**Table 1-3: General Specification**

Specification	Description
Weight	340 lbs (154 kg) approximate
Weight (shipping)	445 lbs (202 kg) approximate
Power consumption	5 kw, nominal operating power, 6.75 kw maximum
Compressor input-power cable (customer-supplied)	Recommended type SO-4 conductor, 600V, neoprene jacket and 10-gauge wire. Install per Figure B.1, electrical schematic diagram, ensuring compliance with all national, state and local standards.
Helium pressure	Static: 195-205 psig (1345-1415 kPa) at 70 to 80°F (21 to 27°C) Return: Normal operation: 75-85 psig (517-590 kPa) at operating temperature.
Ambient operating temperature range	50 to 100°F (10 to 38°C)
Interface	Cold head power receptacles (3): Mates with plugs on cold head power cables. Compressor input-power receptacle: Mates with Hubbel twist lock plug No. 27723 Gas-supply connector: 1/2-inch self-sealing coupling Gas-return connector: 1/2-inch self-sealing coupling Remote control receptacle: 24 VAC 150ma: Mates with P4 connector P/N MS3106A-2, supplied by BROOKS-CRYOGENICS.
Adsorber service schedule	Replace every three years.
Cooling water requirements	70°F water supply, 2.5 gpm, 14 psid (pressure drop: water inlet to water outlet). The pressure value does not consider discharge back-pressure conditions. Maximum/minimum water requirements Maximum outlet temperature 100°F (38°C) Minimum inlet temperature 40°F (4°C) Maximum inlet pressure 100 psig

This compressor has been designed to operate with water having a pH value of 6.0 to 8.0 and a calcium carbonate concentration of less than 75 parts per million (typical municipal drinking water quality). For applications of lower pH or greater hardness, water conditioning may be necessary.

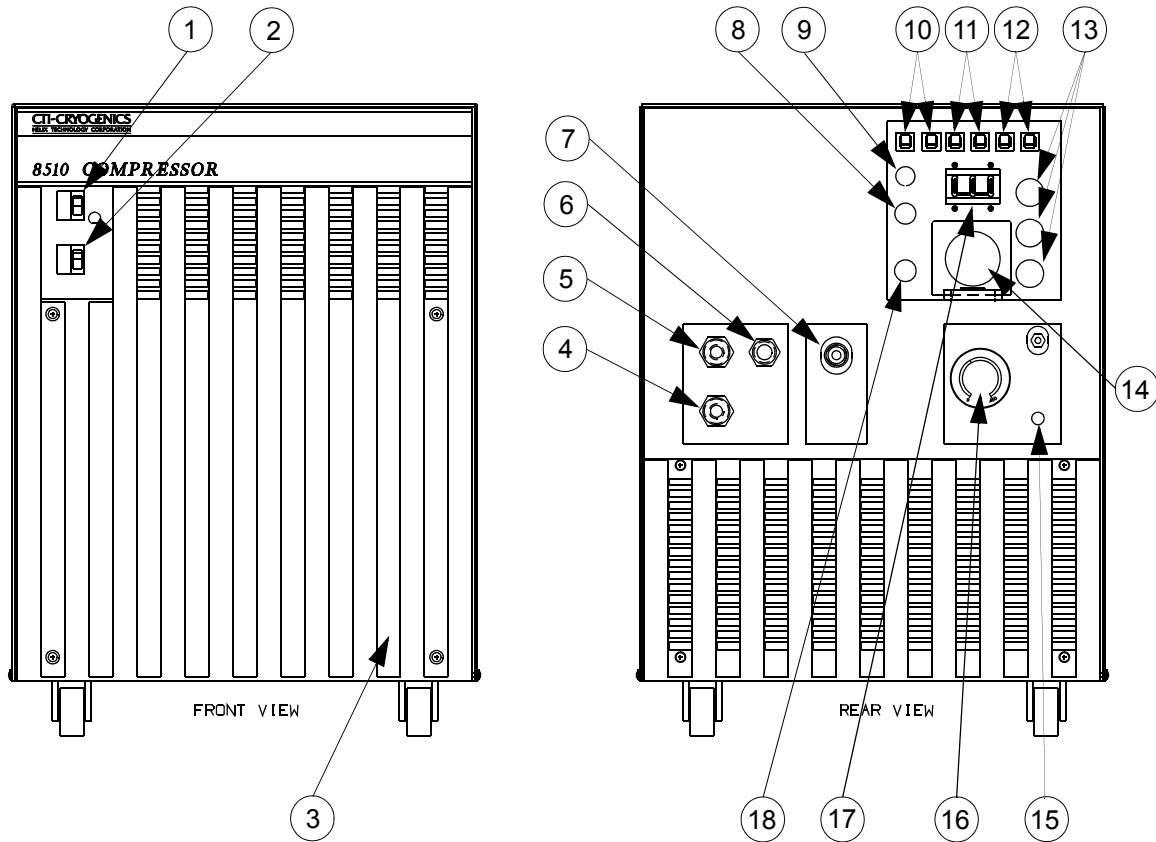

1. Compressor power ON/OFF switch (with ON lamp).
2. On-Board System power ON/OFF switch (with ON lamp).
3. Oil sight glass.
4. Cooling water output.
5. Cooling water input.
6. Helium gas-return connector self-sealing coupling.
7. Helium gas-supply connector self-sealing coupling.
8. Compressor motor starter reset.
9. Voltage selector switch (S3).
10. Heater power circuit breakers (CB4 and CB5).
11. On-Board power circuit breakers (CB6 and CB7).
12. Cold head power circuit breakers (CB2 and CB3).
13. Cold head power cable receptacles (J10, J11, and J12).
14. Input power cable receptacle (J1).
15. Helium gas charge fitting and valve.
16. Helium return pressure gauge.
17. System power ON/OFF switch circuit breaker (CB1).
18. System remote control receptacle (J4).

**Figure 1-2: 8510 Low-Voltage Compressor**

## Section 2 - Inspection

### Packaging of the System

The On-Board High-Vacuum Pump System is packaged in three separate cartons. Listed below are the contents of each carton, as they relate to these two system applications. Note that an Installation, Operation, and Servicing Manual is included in cartons for the high-vacuum pump and compressor. Each manual covers the component packaged in that carton.

When installing an On-Board High-Vacuum Pump System, BROOKS-CRYOGENICS recommends that as you unpack a component; you perform an inspection and the necessary tasks for system installation for the component according to the manual included with the component. Final system installation and operation will be performed following procedures in the On-Board 8/8F or 10 and 400 Cryopump Manual (No. 8040215 or 8040233 respectively).

**Table 2-1: 8510 Shipping Carton Contents**

Carton Label	On-Board 8/8F, 10 And 400 High-Vacuum Pump System Carton Contents	Manual Included
On-Board	On-Board 8/8F Cryopumps	8040215
On-Board	On-Board 10 and 400 Cryopumps	8040233
Compressor	8510 Low-Voltage Compressor	8040232
Accessories	Installation and Scheduled Maintenance Tool Kit and Accessories, P/N 8032040G014	—

### The Compressor

On receipt, remove the 8510 Low-Voltage Compressor from its shipping carton and inspect the compressor for evidence of damage as described in this Section.

1. Unpackage and remove the compressor from its shipping carton.

2. Check the carton contents. It should contain:
  - a. 8510 Low-Voltage Compressor.
  - b. Two barbed fittings for compressor cooling water connections.
  - c. Compressor remote start connector.
  - d. Input power connector.
  - e. Oil prime manifold, P/N 8018129.
  - f. 8510 Low-Voltage Compressor Manual, P/N 8040232.
  - g. Spare fuses.

## Section 3 - Installation

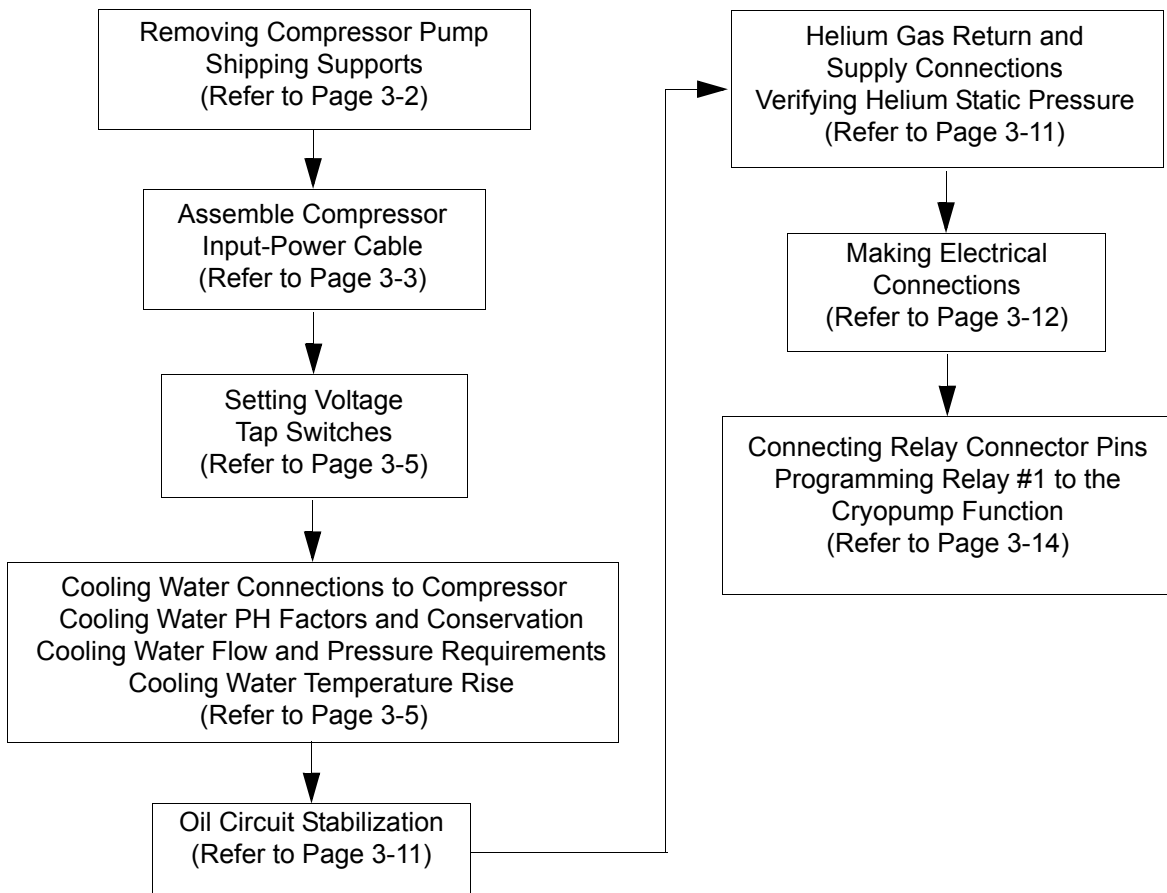

**Figure 3-1: Block Diagram for 8510 Low-Voltage Compressor Installation**

## Compressor Installation

Installation of your compressor requires no special tools other than those supplied in the Installation and Scheduled Maintenance Tool Kit.

### Preparing the Compressor

1. After removing the compressor front panel, refer to [Figure 3-1](#): and remove the front two compressor pump shipping supports.
  - a. Remove the front two nuts and red flat washers that secure the compressor pump tightly in position.

**NOTE:** Retain the two red flat washers for use during shipment.

- b. Remove the two rubber grommets that are in the package attached to the compressor: install them, flat side up, onto the front two mounting posts.
- c. Reinstall the two nuts and screw them down flush with the tops of the mounting posts.
- d. Replace the compressor front panel.

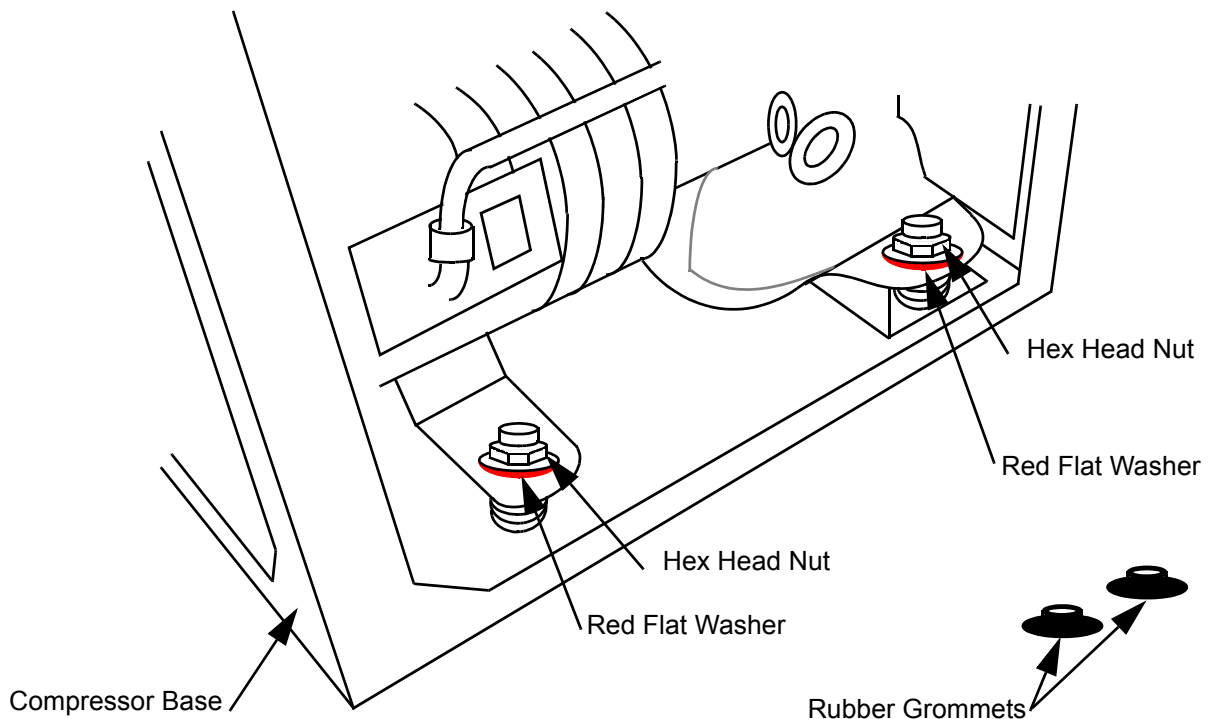

**Figure 3-2: Removing Compressor Pump Shipping Supports**

## Assembling the Compressor Input-Power Cable

### CAUTION

Use round cable (diameter 0.595" to 1.50") with the BROOKS-CRYOGENICS supplied compressor receptacle plug. Do not tin the conductor leads.

Assemble the compressor input-power cable using the BROOKS-CRYOGENICS supplied compressor receptacle plug and a 600-volt power cable that has a SO-4 conductor, 600-volt rating neoprene jacket and 10-gauge wire as follows.

1. Prepare the input power cable by stripping wires and jacket of the cables as shown in [Figure 3-2](#):

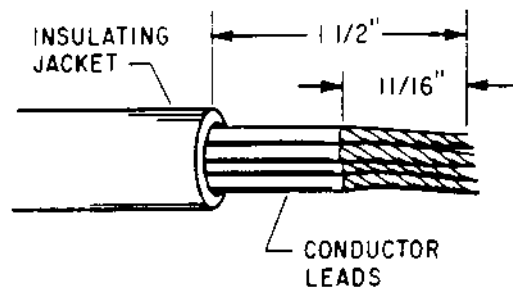
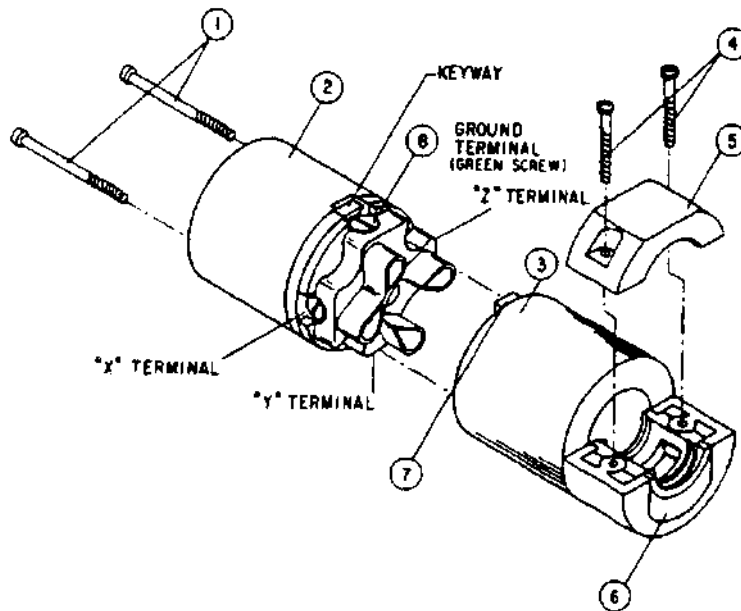

**Figure 3-3: Stripping Compressor Input-Power Cable Insulation**

2. Disassemble the receptacle plug. See [Figure 3-4](#):
  - a. Loosen the two assembly screws (1) securing the receptacle plug face (2) to the cover (3) until plug face can be removed from cover.
  - b. Open cord clamp (5) by loosening the two clamp screws (4) securing the clamp to the cover.

**NOTE:** If you are using cable with a diameter greater than 0.895 inch, remove the auxiliary insert (6) from the cover.

- c. Insert the stripped end of the power cable into the cover opening by starting from clamp end (6) until the stripped conductor ends are exposed.
- d. Loosen and back off all terminal screws on receptacle plug face (2).



**Figure 3-4: Input Power Cable Receptacle Plug**

- e. Insert all conductors into their proper wire entrance holes on receptacle plug face. See [Figure 3-5](#). Check that there are no bare conductors exposed. Tighten terminal screws to 9-12 in.-lbs. torque. Users with 3-phase power, where one phase is at or near ground potential, must connect to the compressor as shown in [Figure 3-5](#):



### WARNING

For installation where one of the 3-phase legs is at or near ground potential, connect that leg to terminal X on the compressor, as shown in [Figure 3-5](#):



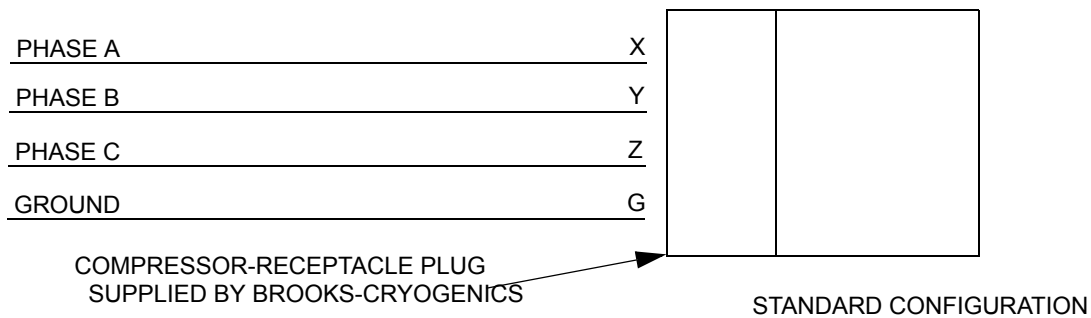

**Figure 3-5:. Wiring Diagram For Standard And Grounded Delta Configurations**

3. Assemble the receptacle plug by sliding the cover over the wire assembly noting key (7). Align the key on the cover to the keyway on the plug face and tighten the two assembly screws (1) to secure the cover and plug face. Alternately tighten the clamp screws (4) to 8-10 in.-lbs. torque.



**WARNING**

Insure that the ground wire is returned to the equipment grounding conductor of the circuit supplying the receptacle.

4. Refer to **8510 Low-Voltage Compressor Electrical Phase Check and Automatic ON/OFF Control**, for correct phasing checkout procedure.

Do not connect the compressor to the power source at this time. All of the preparation must be completed and all the panels reinstalled before electrically connecting the compressor.

### Electrical Preparation Of Compressor Control Module

1. Refer to [Table 1-2:](#) for electrical power requirements. Then, using a voltmeter, measure the phase-to-phase voltage from the power source.
2. Prepare the compressor voltage selector switch S3 as required in accordance with [Figure 3-6:](#)

### Cooling Water: Preparation

If flexible water hose connections are used, install the barbed fittings supplied with the compressor on the input and output connections:

1. Apply a light coating of standard plumbing thread sealant on the barbed fitting threads.

2. Tighten fittings on 1/2-inch FPT input and output connections. DO NOT OVERTIGHTEN.
3. Connect flexible hoses to the fittings and secure with hose clamps.

If hard piping is desired, install the water lines directly onto the compressor 1/2-inch FPT input and output connections. DO NOT OVERTIGHTEN.

### CAUTION

Check water connections for leaks.

### Cooling Water: General Considerations

*NOTE: Adjust your water flow to maintain an optimum discharge water temperature of 80° F with a minimum input pressure of 7 psi. For detailed water requirements, see below.*

1. Cooling water must meet flow and pressure requirements as indicated in the following subsections.
2. Cooling water should have a pH value of 6.0 to 8.0 and a calcium-carbonate concentration of less than 77ppm. The quality of typical municipal drinking water is generally acceptable. If the cooling water has a pH value lower than 6.0 or a calcium-carbonate concentration higher than 77 ppm, water conditioning may be required.
3. To conserve water, the cooling water should be shut off when the compressor is not running.

### CAUTION

If cooling water below 45° F (7° C) is allowed to run through the compressor while the compressor is not operating, the compressor oil will change viscosity and thicken, causing the compressor to overheat and shut off at startup. In this event, repeatedly restart the compressor and allow it to run until it has shut off several times. The oil temperature will rise and thereby allow continuous compressor operation.

4. Drain and purge water from the compressor before shipping it back to the factory or subjecting it to freezing conditions. Purge water from the compressor by blowing compressed air, regulated to 30 to 40 psig (200 to 275 kPa) into the compressor output connection and allowing water to exit from the water input connection.

### Cooling Water: Flow and Pressure Requirements

#### CAUTION

If your water supply pressure falls below 7psig due to back pressure, the compressor will overheat and shut down.

Use the two graphs in [Figure 3-7](#): to determine the minimum acceptable cooling water supply pressure at different flow rates and temperatures. Find the minimum pressure:

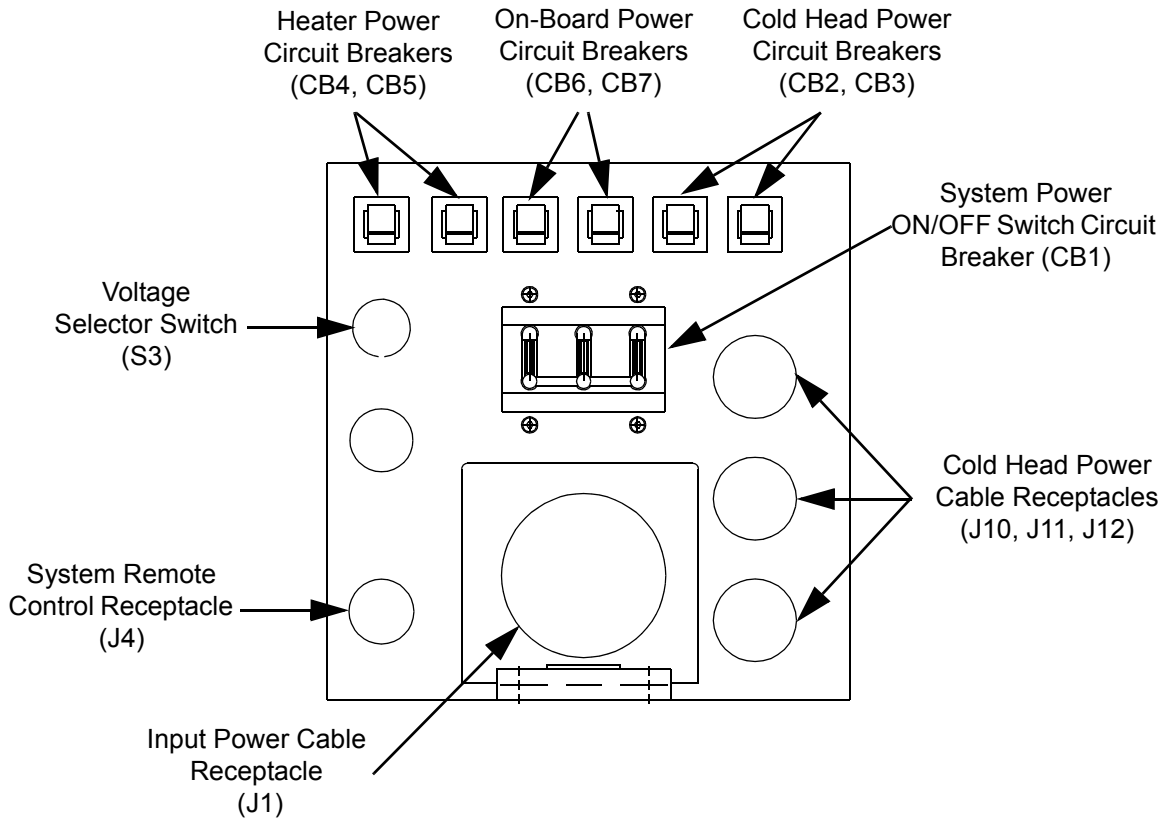

**Figure 3-6: Preparing the 8510 Low-Voltage Compressor Control Module**

**Table 3-1: Compressor Control Module Specifications**

Compressor Configuration	Frequency (Hz)	Voltage	Voltage Selector Switch S3 Setting
P/N 8031315 220/ 230 VAC, 50/60 Hz	50	190-210*	Low
	50	210-230	Med
	60	198-230*	Low
	60	230-250	Med
*Factory setting			

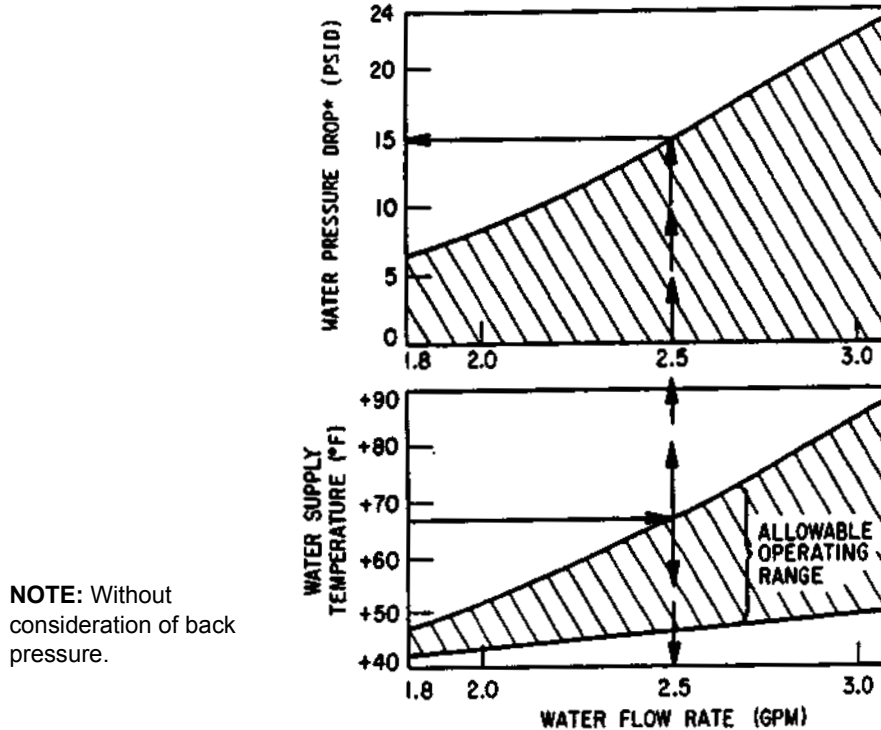

**Figure 3-7: 8510 Compressor Cooling Water Flow And Pressure Requirements**

1. Determine the temperature of the cooling water. Allow a  $\pm 10^{\circ}$  F to the present water temperature if a variation cannot be ascertained. Plot the high and low temperatures on the vertical axis of the lower graph.

The example describes cooling water that varies between  $45^{\circ}$  F and  $67^{\circ}$  F.

2. Determine the optimum water flow rate by drawing a horizontal line from the upper temperature variation figure on the lower graph to the upper curve of the allowable operating range indicated by cross-hatching. Draw a line from this intersecting point straight down to the horizontal axis to find the optimal flow rate.

The example shows a solid arrow extending from  $67^{\circ}$  F and intersecting the allowable operating range. Dashed arrows pointing downward indicate a water flow rate of 2.5 gallons per minute.

3. Determine the cooling water supply pressure drop by drawing a straight line up from the flow rate in the lower graph to the upper graph. At the point at which this line intersects the upper graph, draw a line leftward to the vertical axis and find the water supply pressure drop.

The example shows dashed arrows extending from the lower to the upper graph. On the upper graph the dashed arrows intersect the graph curve at approximately 15 psig.

4. Determine the total cooling water supply pressure drop by adding the pressure drop determined from the graph to the water back pressure at the installation site.

### Cooling Water: Temperature Rise

#### CAUTION

The temperature of the cooling water as it leaves the compressor should not exceed 100° F.

Use the graph in [Figure 3-8](#): to determine the rise in cooling water temperature as it passes through the compressor. The recommended discharge temperature for the compressor is 80° F. This information is used by plant engineering personnel to determine cooling water requirements.

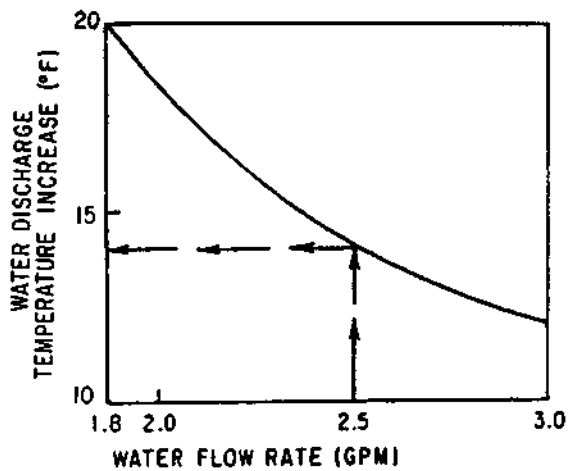

**NOTE:** Used for clarification of example presented in text.

**Figure 3-8: 8510 Compressor Water Discharge Temperature Increase ° F**

Find the temperature rise:

1. Draw a vertical line upward from the horizontal axis of the graph at the water flow rate determined from the previous section, until it hits the graph curve.

The example shows dashed arrows pointing upward to the graph curve from 2.5 gpm on the water flow rate axis.

2. At the point which the dashed arrows intersect the graph curve, draw a straight line to the left to obtain the increase in output water temperature.

The example shows a temperature increase of 14° F.

### Oil Circuit Stabilization

1. Check to insure that the cover and all panels are properly installed on the compressor.
2. With the system power ON/OFF switch in the OFF position, connect the input-power cable to the power source. If necessary, refer to [Table 1-1](#): for electrical requirements.
3. Place the system power switch to the ON position and allow the compressor to run 15 minutes to stabilize the oil circuit. If the compressor shuts down, oil system priming may be necessary. Refer to **Section 4 - Maintenance Procedures** for compressor oil priming procedures.

### Connecting the Compressor to the Cryopump

***NOTE:** If your application requires the use of multiple compressors on a single gas manifold, you must install an external check valve on each compressor. Order BROOKS-CRYOGENICS' Kit No. 8080275K004 and contact the Product Service Department for installation guidance on manifolding compressors.*

Make the connections between the cryopump and compressor. See [Figure 3-9](#):

1. Remove all dust plugs and caps from the supply fittings and return lines, compressor, and cryopump cold head. Check all fittings.
2. Connect the helium-gas return line from the gas return connector on the rear of the compressor to the gas-return connector on the cryopump cold head.
3. Connect the helium-gas supply line from the gas-supply connector on the rear of the compressor to the gas-supply connector on the cryopump cold head.
4. Attach the supply and return line identification decals (BROOKS-CRYOGENICS supplied) to their respective connecting piping ends.

Verify proper helium supply static pressure by confirming that the helium pressure gauge reads 195-205 psig (1345-1415 kPa), in an ambient temperature range of 50 to 100° F (10 to 38° C).

If the indicated pressure is higher than 205 psig (1415 kPa), reduce the pressure as follows:

1. Remove the flare cap from the gas charge fitting located on the rear of the compressor.
2. Open the gas charge valve **very slowly**. Allow a slight amount of helium gas to escape until the helium pressure gauge reads 200 psig (1380 kPa).
3. Close the gas charge valve and reinstall the flare cap.

If the indicated pressure is lower than 195 psig (1345 kPa), add helium gas as described in **Section 4 -Maintenance Procedures**.

## Electrical Connection of Compressor



### WARNING

The system power switch on the rear of the compressor must be in the OFF position before making any and all electrical connections.

1. Connect the power cable to the rear panel of the compressor and the other end to the electrical power connector on the cryopump.
2. Plug the compressor input power cable into the power source.
3. Turn the system power switch on the rear of the compressor to the ON position.



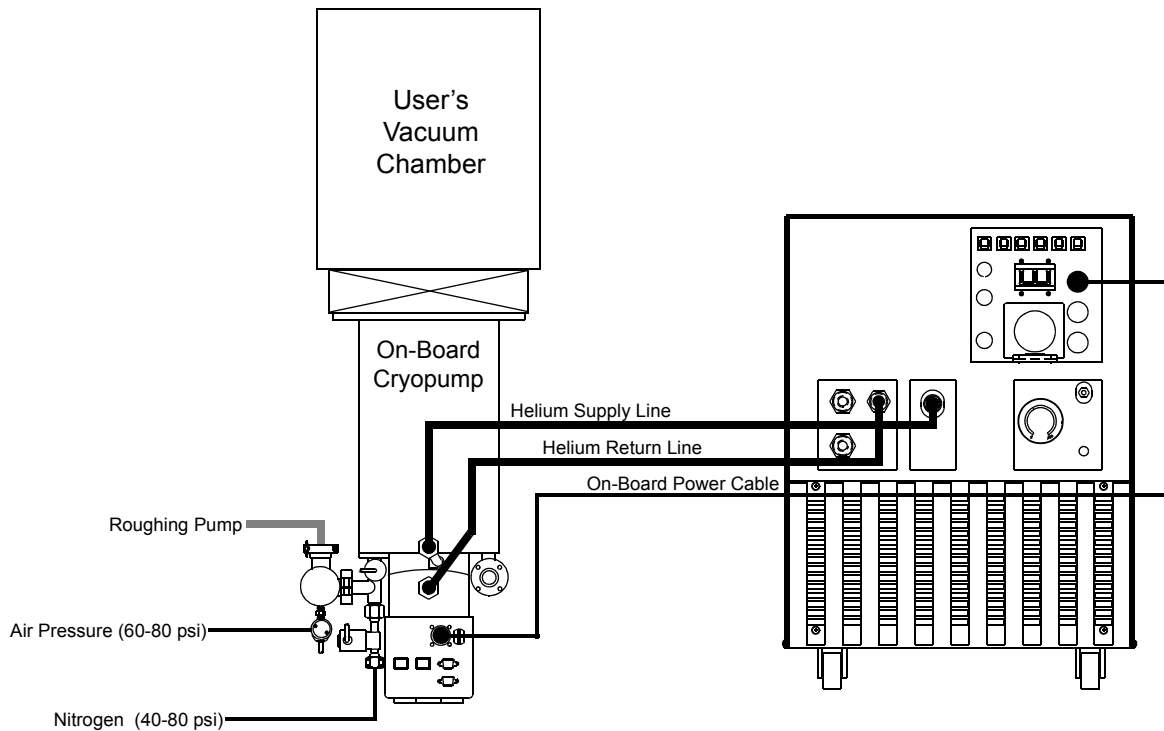

**Figure 3-9: 8510 Low-Voltage Compressor Installation**

## 8510 Low-Voltage Compressor Electrical Phase Check and Automatic ON/OFF Control

### System Phase Input Checkout Procedure

To check that the correct phasing is being supplied to the On-Board cryopump, proceed as follows:

1. Press **CONTROL** key on the On-Board keypad.
2. Press **1** to turn the cryopump on.
3. If the cryopump turns on, keypad displays *CRYO ON* the system phasing is correct.
4. Press **0** to turn cryopump off.
5. If the cryopump does not turn on when 1 is pressed, keypad display reads *NO CRYO POWER 2* . This means that ***incorrect phasing is being supplied to the 8510 Compressor*** from its power source.
6. To correct the phasing, interchange any two of the three phase wires at the compressor receptacle plug. See [Figure 3-5](#):

## Automatic ON/OFF Control of the 8510 Low-Voltage Compressor Using the On-Board Setpoint Relays

The 8510 Low-Voltage Compressor remote start feature can be used with one of the On-Board setpoint relays to automatically turn the compressor on when the cryopump is turned on and turn it off when the cryopump is turned off. Disconnect the jumper on the “jumper” connector supplied and installed on the compressor REMOTE connector J4. Connect the electrical leads from the On-Board relay using 18 awg or larger wire (2.7A inductive load) to the remote connector as follows:

**Table 3-2: Electrical Leads**

On-Board Relay Connector	8510 Remote Connector (J5)
Pin #8	A
Pin #6	B

Now program Relay 1 to the cryopump function as described below.

1. Press the **RELAY** function key.
2. Select Relay 1 by pressing **1**.
3. Press the **Next** key until the display reads *CRYOPUMP*.
4. Press **Enter** and the display should read *FNC = CRYOPUMP* (function is cryopump operation).
5. Press the **CONTROL** function key. Programming is complete.

**NOTE:** Be sure that the compressor switch is off before connecting or disconnecting the remote connector.

## Multipump Installation

Your 8510 Low-Voltage Compressor can be connected to more than one high-vacuum pump at a time. For example, three On-Board 8 vacuum pumps can be connected to a single 8510 Low-Voltage Compressor.

### CAUTION

For detailed instructions on multiple Cryopump installation, refer to Appendix F.

## Section 4 - Maintenance Procedures

### WARNING

Always disconnect the compressor from all sources of electrical power before performing any maintenance procedures.



Unit must be wired by an authorized electrician in accordance with the national Electrical Code, ANSI/NFPA 70-1987, as well as the local codes. This shall include installation of a readily accessible disconnect device into the fixed wiring supplying power.

An insulated safety grounding conductor that is identical in size, insulation material and thickness to the circuit supply conductors, except that it is green with or without one or more yellow stripes is to be installed as part of the branch circuit which supplies the unit or system. The grounding conductor described is to be connected to equipment grounding conductor of the supply circuit.

### Scheduled Maintenance

The only scheduled maintenance required on the 8510 Low-Voltage Compressor is replacement of the compressor adsorber (P/N 8080275K001) every three years.

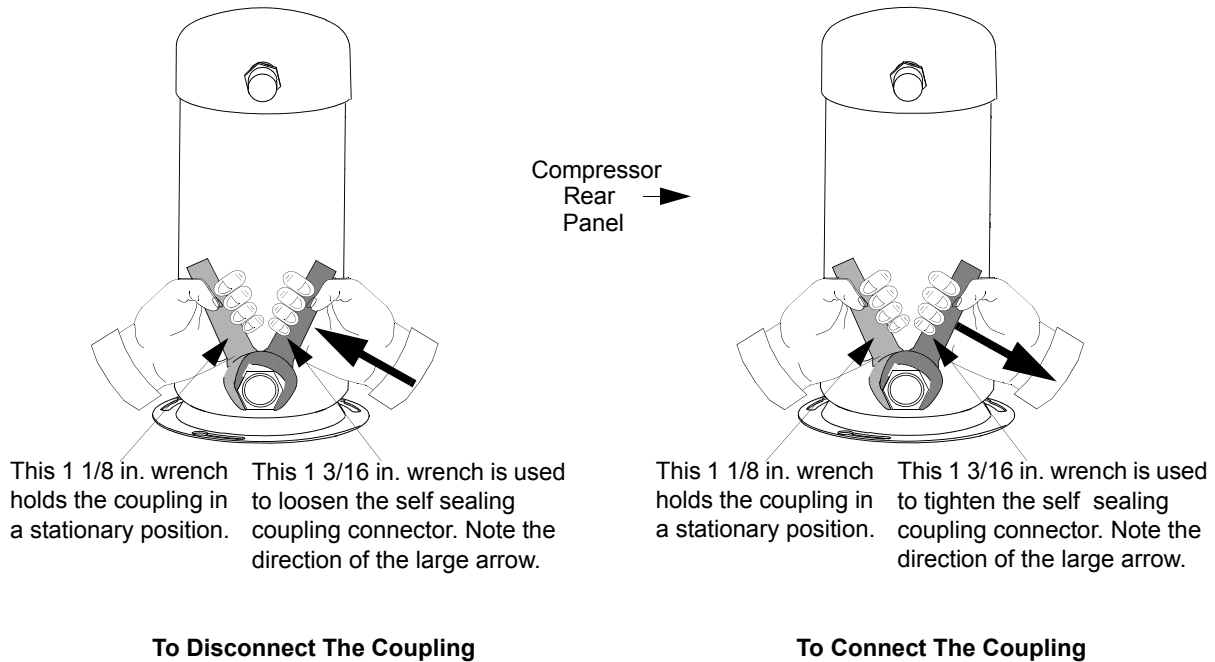

**Figure 4-1: Disconnecting/Connecting the Adsorber Self-Sealing Couplings**

### Removing the Compressor Adsorber

To remove the compressor adsorber see [Figure 4-1](#): and proceed as follows:

1. Shut down the compressor.
2. Disconnect the compressor input power cable from its electrical power source and disconnect the water lines.
3. Disconnect the flex lines from the gas-return and gas-supply connectors at the rear of the compressor.

**NOTE:** Use the two wrenches supplied in the Installation and Scheduled Maintenance Tool Kit to avoid loosening the body of the coupling from its adapter. Hold one wrench fast on the coupling half attached to the rear side of the compressor. Use the other wrench to loosen the coupling on the helium supply or return line.

4. Loosen the four screws that hold the compressor rear panel and remove the panel.
5. Disconnect the adsorber-inlet self-sealing coupling. See [Figure 4-1](#):
6. Remove the bolts, nuts, and washers that secure the adsorber to the base of the compressor. Save all hardware.

7. Carefully slide the adsorber outward until it clear the compressor and remove the adsorber.



### WARNING

Depressurize the adsorber before disposing of it. Attach the depressurization fitting (included in the Installation and Scheduled Maintenance Tool Kit) to the coupling half at either end of the adsorber and tighten it slowly. Installing the Compressor Adsorber

1. Install the replacement adsorber as follows:
  - a. Remove the dust caps from the self-sealing coupling halves at each end of the replacement adsorber.
  - b. Install the replacement adsorber following the steps for compressor adsorber removal in reverse order. Use the hardware saved from adsorber removal.
2. Connect the adsorber to the compressor internal piping as follows:
  - a. Check the self-sealing connector flat rubber gasket to make sure that it is clean and properly positioned.
  - b. Make the first turns by hand and then firmly seal the connection using the two wrenches until the fittings “bottom”.

### CAUTION

Make sure to hold fast on the left coupling nut while tightening the right coupling nut, as shown in [Figure 4-1](#):

- c. Using the two wrenches supplied in the Installation and Scheduled Maintenance Tool Kit, make the connection quickly to minimize minor gas leakage. See [Figure 4-1](#):
3. Replace the panel and secure it by tightening the four screws.
4. Ensure that the pressure gauge reads 195-205 psig (1345-1415 kPa). If additional gas pressure is required, follow the instructions under, **Adding Helium Gas**. Record the date that the adsorber was replaced, and also make a note that the next adsorber replacement is in three years.
5. Connect the flex lines to the gas-return and gas-supply connectors at the rear of the compressor.

6. Connect the water lines to the compressor fittings and secure with hose clamps. If hard piping is used, apply a light coating of plumbing thread sealant on threads and install water lines onto the compressor. **DO NOT OVERTIGHTEN.**

**CAUTION**

Check water connections for leaks.

7. Connect the cold head power cables to the compressor connectors.
8. Plug the compressor input power cable into the power source.

## Unscheduled Maintenance

### Suggested Unscheduled Maintenance Equipment

It is advisable to keep on hand the unscheduled maintenance equipment and disposable supplies listed below.

1. Helium, 99.999% pure.
2. Pressure regulator (0-3000/0-400 psig).
3. Maintenance manifold, P/N 8080250K003\*.
4. Helium charging line terminating in a 1/4-inch female flare fitting, P/N 7021002P001.
5. Installation and Scheduled Maintenance Tool Kit, P/N 8032040G014.

\*Available from stock; consult the factory or your sales representative.

### Adding Helium Gas

Use only 99.999% pure helium gas.

**CAUTION**

If the compressor helium pressure gauge reads 0, decontamination is required. Refer to **Helium Circuit Decontamination** within this section or contact the Product Service Department.

1. A user-supplied helium charging line terminating in a 1/4-inch female flare fitting, and a two-stage pressure regulator rated at 0-3000/0-400 psig is required for this operation.

2. If you need to add helium more than once every several months, check for leaks caused by improperly connected self-sealing connections or any mechanical joint within the compressor.

There are two conditions that require the addition of helium gas:

1. Compressor not operating; helium pressure gauge reads 195 psig (1345 kPa), or below.
2. Compressor operating; helium pressure reads 75 psig (517 kPa), or below.

To add helium gas:

1. Attach a two-stage regulator (0-3000/0-400 psig) and charging line to a helium gas (99.999% pure). **DO NOT OPEN THE BOTTLE AT THIS TIME.** Purge the regulator and charging lines as instructed in steps a through e below. Do *not* use helium gas that is *less than 99.999% pure*.
  - a. Open the regulator a small amount by turning the adjusting knob clockwise until it contacts the diaphragm, then turn approximately 1/8 to 1/4 turn more, so that the regulator is barely open.
  - b. Slowly open the bottle valve, and purge the regulator for 10 to 15 seconds. Turn the regulator knob counterclockwise until the helium stops flowing.
  - c. Connect the charge line to the helium pressure regulator.
  - d. Remove the flare cap of the gas charge fitting on the rear of the compressor. Loosely connect the charge line to the charge fitting.
  - e. Set the helium pressure regulator to 10 to 25 psig (70-125 kPa). Allow helium gas to flow through the charging line and around the loosened flare fitting for 30 seconds to purge the charging line of air. Then tighten the flare nut at the end of the charge line.

(This procedure is required to ensure that both the regulator and the charging line will be purged of air and that the air trapped in the regulator will not diffuse back into the helium bottle. For best results, BROOKS suggests a dedicated helium bottle, regulator, and line, which are never separated, for adding helium.)

2. Set the helium pressure regulator to 300 psig (2070 kPa). Depending on the compressor operating state, add helium gas:
  - a. If the compressor is running (approximately 2 hours operat-

- ing time) under normal operating conditions, slowly open the helium charge valve on the rear of the compressor. When the helium pressure gauge rises to 75-85 psig (517-590 kPa) tightly close the charge valve.
- b. If the compressor is not running, slowly open the helium charge valve. When the helium pressure gauge rises to 195-205 psig (1345-1415 kPa), tightly close the charge valve.

### CAUTION

Add helium gas slowly to prevent relief valve blow-off.

3. Ensure that the helium charge valve on the compressor is tightly closed. Shut off the helium pressure regulator on the helium bottle and remove the charging line from the male flare fitting. Shut off the helium gas bottle valve. Reinstall the flare cap.

### Helium Circuit Decontamination

Contamination of the helium-gas circuit is indicated by sluggish or intermittent operation (ratchetting) of the cold head drive mechanism. With severe contamination the cold head drive may seize and fail to operate. One of the major sources of contamination is using helium gas of less than the required purity. When performing the decontamination process, use only 99.999% pure-helium gas, and the regulator and charging line must be properly connected and purged. This contamination procedure will remove contaminants from the cold head and/or compressor, thereby restoring system performance. The cold-trapping of contaminants inside the cold head during this procedure will also decontaminate the compressor if the contamination of the system is not severe. Separate decontamination of the compressor is required whenever the compressor has been opened to atmosphere, or the pressure dropped to zero.

### Cryopump Decontamination Procedures

1. Cool down the cryopump and operate it for one to three hours. If the system will not cool down, proceed to step 2. Operating the cryopump will isolate the contaminants by “freezing” them in the cold head. The contaminants in the helium-gas circuit of the cryopump tend to become frozen inside the cold head. The longer the cryopump is operated beyond the one-hour period, the greater is the amount of contamination that becomes isolated inside the cold head.
2. Shut down the compressor as follows:



- a. Close the Hi-Vac valve in your vacuum system.
- b. Turn off the system power ON/OFF switch.

### CAUTION

Exposing the cryopump to atmosphere during warm-up will cause excessive water vapor adsorption by the charcoal of the 15K array.

3. **Immediately** disconnect the helium-gas supply and helium-gas return lines from the gas-supply and gas-return connectors at the rear of the compressor. Leave them attached to the cold head.
4. Attach the maintenance manifold (P/N 8080250K003) to the disconnected ends of the helium-gas return and helium-gas supply lines.
5. Reduce the pressure in the cold head to a level of 45 psig by using the maintenance manifold.
6. If you have the automatic REGEN ON-BOARD option, start a regeneration and then discontinue it when the cryopump reaches 300K. If you only have the manual regeneration option, turn the cryopump off and open the purge valve until the second stage reaches room temperature.
7. Allow the second stage of the cold head to warm up to room temperature. Warm-up time can be reduced by purging the cryopump with warm dry argon or nitrogen gas. Using the gas heater, BROOKS P/N 8080250K020, will reduce warm-up time about 50 percent, and will maintain the gas temperature below the 150°F (66°C) limit.
8. Once the cryopump has reached room temperature, attach a two-stage regulator (0-3000/0-400 psig) and charging line to a helium bottle (99.999% pure). **DO NOT OPEN THE BOTTLE VALVE AT THIS TIME.** Purge the regulator and charging line as instructed in steps a through e in **Adding Helium Gas**. Do *not* use helium gas that is *less than 99.999% pure*.
9. Perform in sequence:
  - a. Backfill the cold head and helium-gas return and supply lines with helium to a static charge pressure of 195-205 psig (1345-1415 kPa) by adjusting the regulator to the required pressure, and opening the valve on the manifold. Close the valve when the pressure is correct.
  - b. Depressurize the cold head by *slowly* opening the ball valve

- and allowing the helium to bleed out slowly. Do *not* reduce the pressure to *less than* 30 psig or the cold head may be further contaminated.
- c. Perform flushing steps a and b three more times.
  - d. Pressurize the cold head to the static charge pressure of 195-205 psig (1345-1415 kPa) and run the cold head drive motor for 10 to 30 seconds by actuating the controller ON/OFF switch to on.
  - e. Perform steps b through d three more times for a total of 16 flushes and a total of 4 drive-motor runs.
10. Verify that the cold head is pressurized to the static charge pressure of 195-205 psig (1345-1415 kPa).
  11. Disconnect the maintenance manifold from the helium-gas return and helium-gas supply lines.
  12. Reconnect the helium-gas return and helium-gas supply lines to the return and supply connectors at the rear of the compressor. The cryopump is now ready for operation.

### Compressor Decontamination Procedures

The procedure to decontaminate a compressor is similar to the above procedure with certain exceptions.

- There is no need to operate the cryopump before decontaminating the compressor.
  - The maintenance manifold and helium-gas supply and helium-gas return lines will be connected to the supply and return fittings on the compressor.
1. Open the ball valve slightly on the maintenance manifold and allow the helium to bleed out and depressurize the compressor (if pressurized) to 30 psig.
  2. Charge the compressor slowly to approximately 200 psig (1380 kPa) by opening the 1/8-inch valve on the maintenance manifold.
  3. Run the compressor for about 30 seconds.
  4. Repeat steps 1 and 2, one time.
  5. Disconnect the maintenance manifold from the helium-gas return and helium-gas supply lines.
  6. Reconnect the helium-gas return and helium-gas supply lines to the return and supply connectors on the cold head. The compressor is now ready for operation.

**NOTE:** After connecting the compressor to the cryopump, and operating the system for a period of time, it may be necessary to decontaminate the cryopump as some residual contamination from the compressor may become trapped in the cold head. If the entire system was reduced to zero psig (a broken flex line, for example), then the cryopump and compressor would have to be decontaminated according to the cryopump decontamination. Refer to **Helium Circuit Decontamination** within this section.

### Priming the Compressor Oil System

The oil-prime manifold (P/N 8018129) supplied with the 8510 Low-Voltage Compressor is used to prime the compressor oil system when any of the following conditions exist:

1. The compressor has been inoperative for a period of three months or longer.
2. The compressor is not operating and the supply pressure gauge reads 0 psig. If this condition exists contact the Product Service Department for corrective action before priming the compressor.
3. The compressor has automatically shut off because of a loss of helium supply pressure.

Priming procedures are:

1. Disconnect the helium return and supply lines from the rear of the compressor.
2. Install the oil-prime manifold on the compressor supply and return connectors.
3. Ensure that the pressure gauge reads 195-205 psig (1345-1415 kPa). If additional gas pressure is required, follow the instructions under, **Adding Helium Gas**.
4. Turn the compressor switch to the ON position and allow the compressor to run between 15 and 30 minutes.
5. After completing the oil-system priming turn off the compressor and remove the oil-prime manifold.
6. Reconnect the helium return and supply lines on the rear of the compressor.

*This Page Intentionally Left Blank*

# Appendix A - Customer Support Information

## Customer Support Center Locations

To locate a Customer Support Center near you, please visit our website [www.brooks.com](http://www.brooks.com) on the world wide web and select *CONTACT* on the home page.

## Guaranteed Up-Time Support (GUTS®)

For 24-hour, 7-day per week Guaranteed Up-Time Support (GUTS) dial:

**1 800-367-4887** - Inside the United States of America

**+1 508-337-5599** - Outside the United States of America

## Product Information

Please have the following information available when calling so that we may assist you:

- Product Part Number
- Product Serial Number
- Product Application
- Specific Problem Area
- Hours of Operation
- Equipment Type
- Vacuum System Brand/Model/Date of Manufacture

## E-mail

For your convenience, you may also e-mail us at:

[techsupport@brooks.com](mailto:techsupport@brooks.com)

*This Page Intentionally Left Blank*

## Appendix B - Troubleshooting Procedures

### Troubleshooting the Compressor

The compressor troubleshooting procedures are summarized in [Table B-1](#):

### Technical Inquiries

Please refer to Appendix A of this manual for a complete list of the BROOKS-CRYOGENICS' world wide customer support centers.

#### WARNING



Disconnect the compressor before performing any troubleshooting procedures.

The compressor pump is hot after operating. Wait for the pump to cool down before working on the inside of the compressor

Do not change or modify any compressor internal wiring circuits, this may cause failure of the compressor and cold head due to improper phasing.

**Table B-1: Compressor Troubleshooting Procedures**

Problem	Possible Cause	Corrective Action
1) System power ON/OFF switch (CB1) and compressor switch (S1) remains in the ON position when switched on but the compressor will not run. Refer to Figure C-1 for identification of all electrical components.	<p>1) No power coming from the source.</p> <p>2) Insufficient voltage at power source.</p> <p>3) Control circuit fuses missing or blown.</p> <p>4) Improperly wired external remote control circuit. This will apply only if the remote control feature <i>is being</i> utilized.</p> <p>5) Incorrect control circuit voltage.</p> <p>6) Excessive current drawn by the compressor pump has caused the overload relay in the motor contactor (MI) to open.</p>	<p>1) Check source fuses, circuit breakers, and wiring associated with the power source, and repair as needed.</p> <p>2) Verify adequate phase to phase input voltage. Refer to <a href="#">Table 1-2</a>:</p> <p>3) Check control fuses 1FU, 2FU, and 3FU. If any of these fuses are blown, contact the Product Service Department.</p> <p>4) Verify correct installation of remote control feature by referring to <a href="#">Table 3-2</a>:</p> <p>5) Check voltage setting of switch S3, see <a href="#">Figure 3-6</a>:</p> <p>6) a. Reset the overload relay in the motor contactor. Refer to <a href="#">Figure C-1</a>; for its location. b. Contact the Product Service Department.</p>
2) System power ON/OFF switch (CB1) will not remain in the ON position when switched on. The switch circuit breaker trips when excessive current is being drawn by the cold head or 24-volt compressor control circuits.	<p>1) Damaged On-Board power cable, connectors or drive motor.</p> <p>2) Damaged component in the compressor power or control circuit.</p>	<p>1) Check for compressor operation with each cold head connection (P2, P3 or P4) disconnected from compressor. Contact the Product Service Department if the compressor operates improperly.</p> <p>2) Contact the Product Service Department.</p>



**Table B-1: Compressor Troubleshooting Procedures**

Problem	Possible Cause	Corrective Action
3) System power ON/OFF switch (CB1) remains in the ON position, and the compressor stops after several minutes of operation and remains off.	1) Loss or degradation of power coming from power source. 2) Thermal protective switches are open. 3) Very cold cooling water has caused a restriction of oil flow through the oil injection orifice during startup.	1) Ensure a constant supply of power per <a href="#">Table 1-2</a> : 2) Check for inadequate water cooling, see <a href="#">Table 1-3</a> : 3) Recheck for proper cooling water temperature per <a href="#">Table 1-1</a> : Restart the compressor repeatedly until continuous operation is achieved.

*This Page Intentionally Left Blank*

## Appendix C - Electrical Schematic for 8510 Low-Voltage Compressor

**Table C-1: 8510 Fuses**

Fuse Designation	Amp Rating	Bussman* P/N
1FU	1	MDX1
2FU	1	MDX1
3FU	2	MDX2
4FU	3.2	MDL 3 2/10
5FU	3.2	MDL 3 2/10
6FU	3.2	MDL 3 2/10
7FU	0.5	MDL 1/2
8FU	0.5	MDL 1/2
9FU	0.125	MDL 1/8
*Replacement parts must be Bussman type only.		

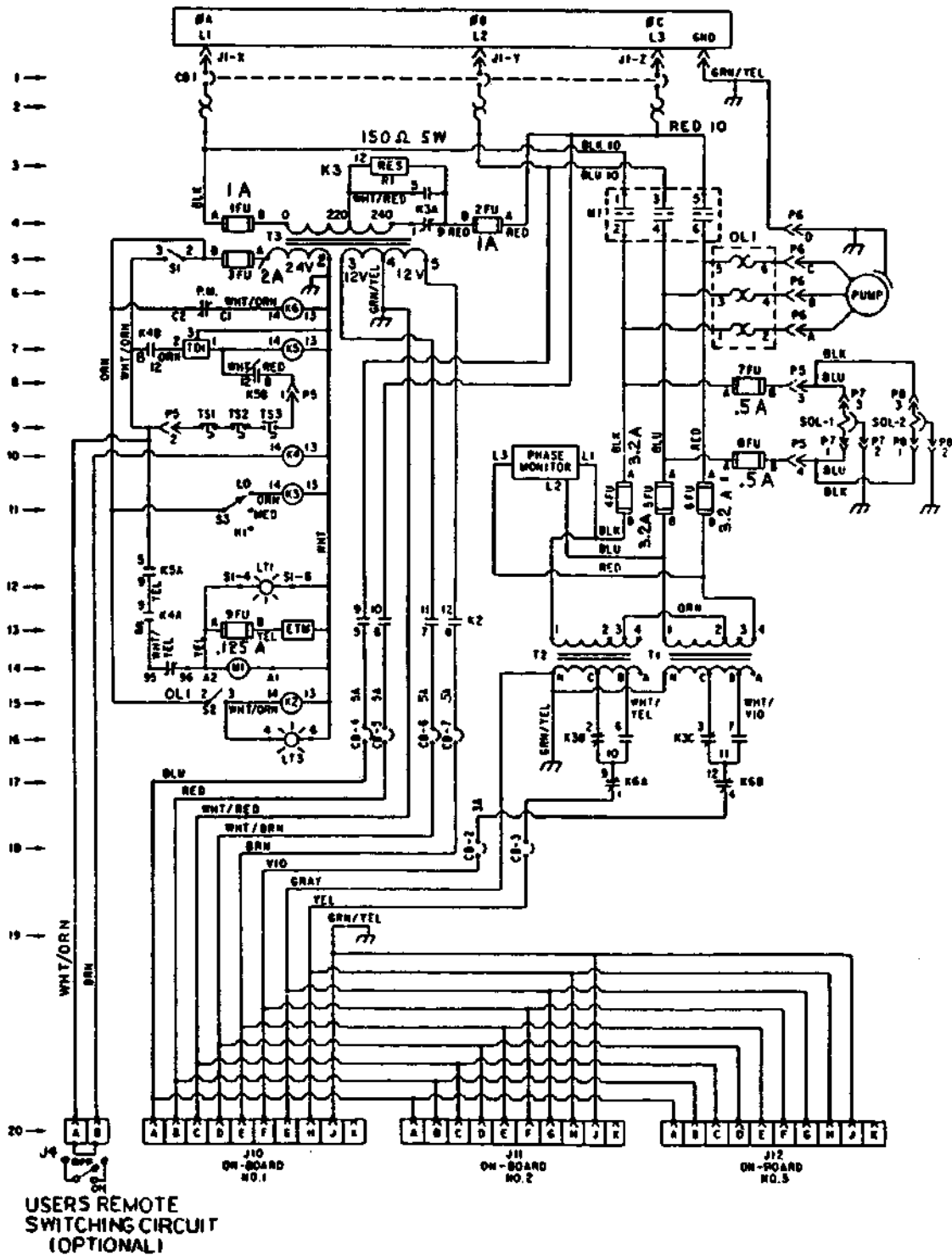

Figure C-1: Electrical Schematic for 8510 Low-Voltage Compressor Drawing No. 8031350 Rev. F

**Table C-2: Legend for Figure C-1**

Component	Description
CB1	Circuit Breaker, 25 Amps, Main Power
CB2 & CB3	Circuit Breakers, 3 Amps, Cryopump Power
CB4 & CB5	Circuit Breakers, 5 Amps, Heater Power
CB6 & CB7	Circuit Breakers, 5 Amps, On-Board Power
ETM	Elapsed Time Meter
J1	Input Power Connector
J4	Remote ON/OFF Connector
J10 Thru J12	On-Board Power Output Connectors
K2	On-Board Power/Cryopump Heater Relay
K3	Voltage Select Relay
K4	Remote ON/OFF Relay
K5	Compressor Start Relay
K6	Cryopump Phase Monitor Relay
M1	Motor Starter
OL1	Motor Overload Protector
PM	Phase Monitor
PUMP	Compressor Pump
R1	Resistor - 150 Ohms, 5 Watts
S1	Compressor Power Switch (With Lamp LT1)
S2	On-Board Power Switch (With Lamp LT3)
S3	Voltage Select Switch
SOL1	Solenoid Valve - Oil Flow
SOL2	Solenoid Valve - Gas Flow
T1 & T2	Cold Head Drive Transformer
T3	Control Transformer, 24 VAC
TD1	Time Delay Relay
TS1	Thermal Protective Switch - Oil Flow/Gas Discharge Temperature
TS2	Thermal Protective Switch - Oil Flow/Motor Temperature
TS3	Thermal Protective Switch - Oil/Water Temperature

*This Page Intentionally Left Blank*

---

# **Appendix D - Electrical Control Module Components of the 8510 Low-Voltage Compressor**

**Table D-1: Legend for Figure D-1**

Item Number	Description	Symbol Designation
1	Cryopump Phase Monitor Relay	K6
2	Compressor Start Relay	K5
3	Remote ON/OFF Relay	K4
4	Voltage Select Relay	K3
5	On-Board Power/Cryopump Heater Relay	K2
6	Time Delay Relay	TD1
7	Control Transformer, 24 VAC	T3
8	Cold Head Drive Transformer	T2
9	On-Board Power Switch (with Lamp LT3)	S2
10	Compressor Power Switch (with Lamp LT1)	S1
11	Cold Head Drive Transformer	ETM
12	Fuse - 0.125A, Slow-Blow, Bussman, MDL 1/8	T1
13	Fuse - 0.5A, Slow-Blow, Bussman, MDL 1/2	9FU
14	Fuse - 0.5A, Slow-Blow, Bussman, MDL 1/2	8FU
15	Fuse - 3.2A, Slow-Blow, Bussman, MDL 3 2/10	7FU
16	Fuse - 3.2A, Slow-Blow, Bussman, MDL 3 2/10	6FU
17	Fuse - 3.2A, Slow-Blow, Bussman, MDL 3 2/10	5FU
18	Fuse - 2.0A, Slow-Blow, Bussman, MDX 2	4FU
19	Fuse - 1.0A, Slow-Blow, Bussman, MDX 1	3FU
20	Fuse - 1.0A, Slow-Blow, Bussman, MDX 1	2FU
21	Fuse - 1.0A, Slow-Blow, Bussman, MDX 1	1FU
22	Resistor - 150 Ohms, 5 Watts	R1
23	Motor Starter	M1
24	Phase Monitor	PM
25	Motor Overload Protector	OL1
26	Voltage Select Switch	S3
27	Motor Starter Reset	M1 Reset
28	Remote ON/OFF Connector	J4
29	Input Power Connector	J1
30	On-Board Power Output Connector	J12
31	On-Board Power Output Connector	J11
32	On-Board Power Output Connector	J10
33	Circuit Breaker, 3A, Cryopump Power	CB3
34	Circuit Breaker, 3A, Cryopump Power	CB2
35	Circuit Breaker, 5A, On-Board Power	CB7
36	Circuit Breaker, 5A, On-Board Power	CB6
37	Circuit Breaker, 5A, Heater Power	CB5
38	Circuit Breaker, 5A, Heater Power	CB4
39	Circuit Breaker, 25A, Main Power	CB1



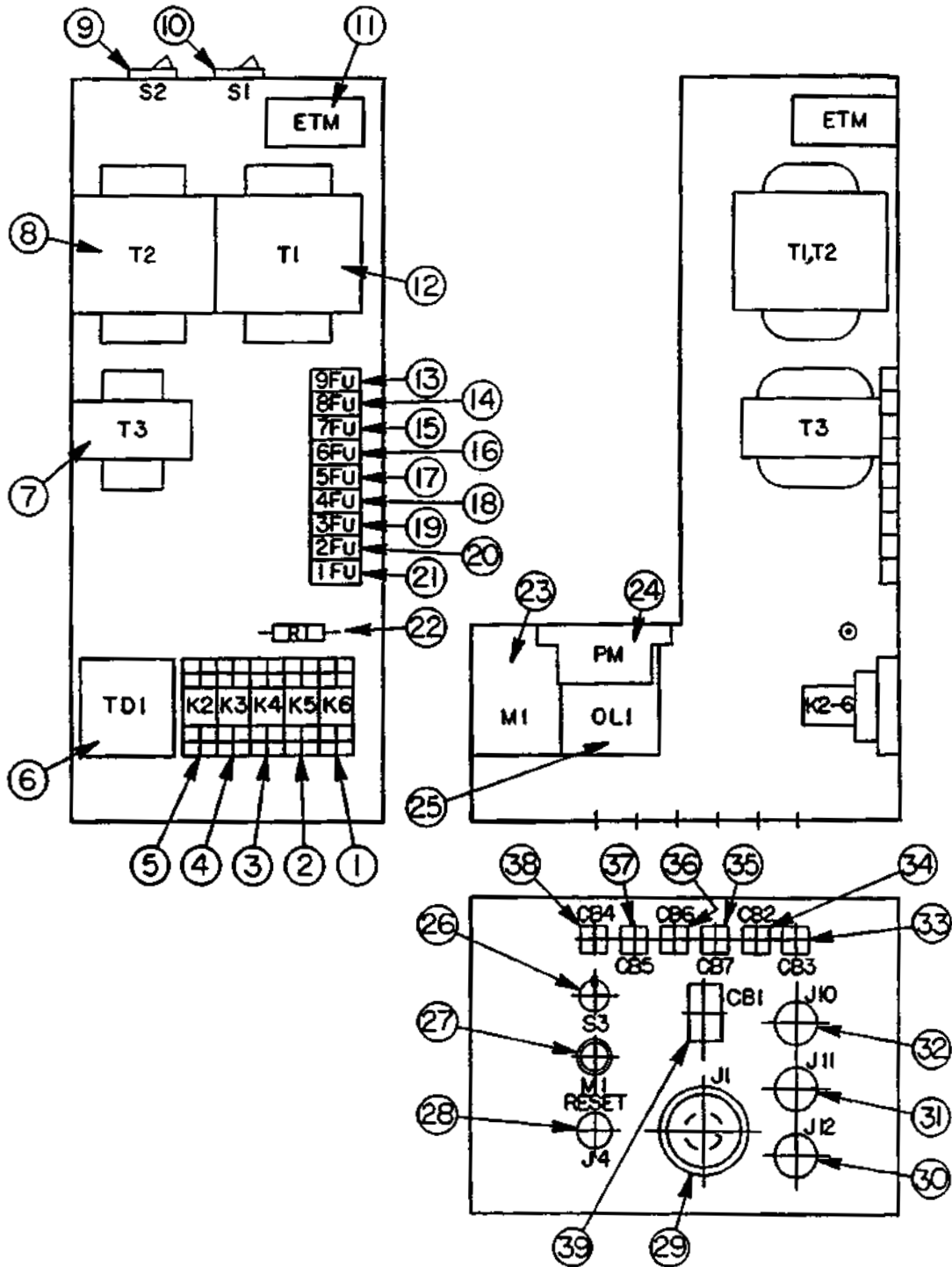

Figure D-1:Electrical Control Module Components of 8510 Low-Voltage

*This Page Intentionally Left Blank*

# Appendix E - 8510 Low-Voltage Compressor Flow Diagram

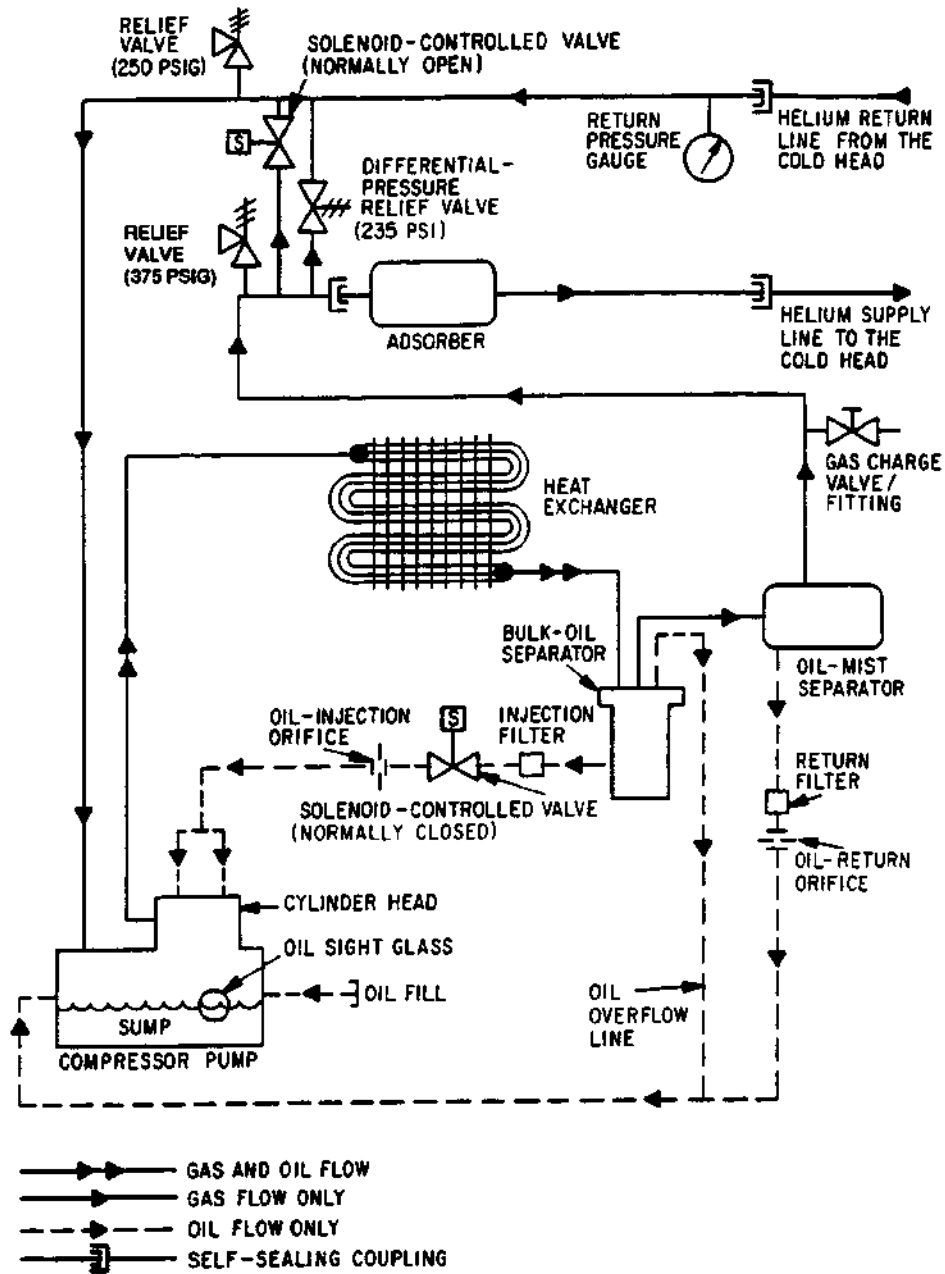

Figure E-1: Flow Diagram of 8510 Low-Voltage Compressor

*This Page Intentionally Left Blank*

## Appendix F - Multiple Cryopump Installation with Single 8510 Low-Voltage Compressor

Your 8510 Compressor may be used to drive a number of multiple On-Board cryopump combinations.

**Figure F-1:** depicts a typical multi-cryopump installation with an 8510 Low-Voltage Compressor. As shown in this figure, a power cable is connected from the compressor to each cold head; also, the components are helium connected in parallel (all supply fittings piped together).

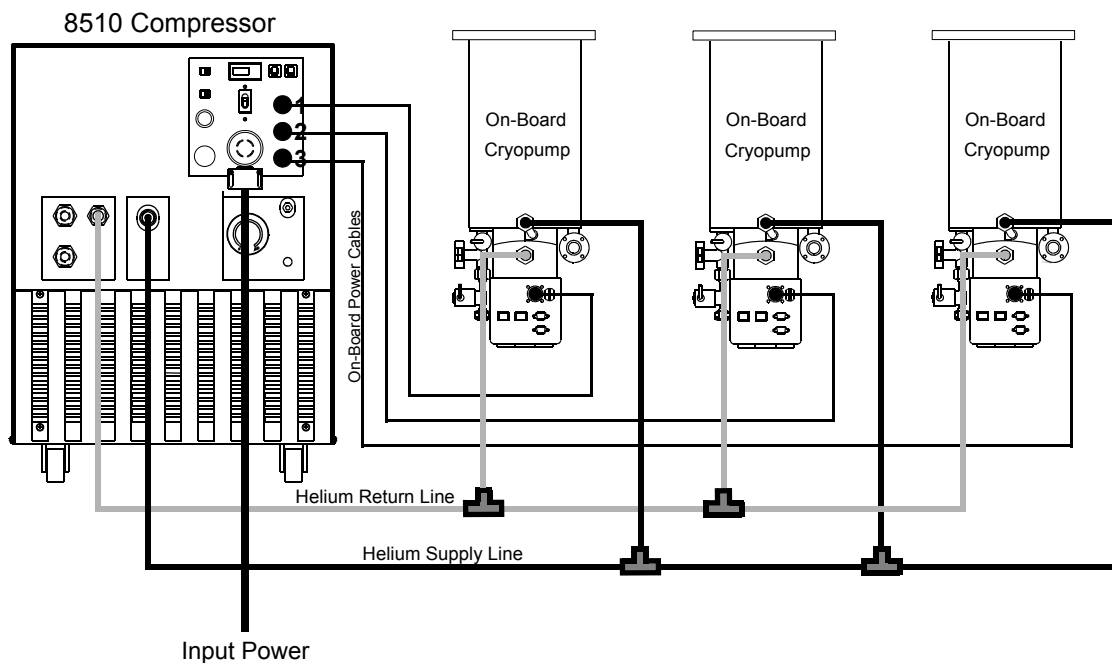

**Figure F-1: Typical Multiple Cryopump Installation with Single 8510 Low-Voltage Compressor**

Shown in **Figure F-1:** is a typical multiple cryopump installation. If you are considering a multiple cryopump installation please contact the BROOKS-CRYOGENICS, U.S.A., Application Engineering Department (1-800-447-5007) for technical assistance in the selection and sizing of the manifolds and interconnecting lines for your particular installation.

## Preliminary System Requirements

Installation of the 8510 Low-Voltage Compressor for use with a single cryopump is covered in **Section 3 - Installation**. Installation for multiple cryopump usage is similar, but requires that system charge pressure be established for a given high-vacuum pump system. Additionally, the following parameters must be considered before the system can be assembled.

- All system components must be assembled and be operational for system static charge pressure determination.
- All system components must have static charge pressures of 195-205 psig at 70° F to 80° F (21° C to 27° C).

## Determining System Charge Pressure

To establish the helium gas charge pressure of a multiple cryopump installation proceed as follows:

1. Assemble your multiple cryopump system components.
2. Check the compressor pressure gauge to insure static pressure is in the 195-205 psig (1345-1415 kPa) range.
3. If it is necessary to reduce helium gas pressure then perform the following:
  - a. Disconnect the charging line from gas charge fitting on rear of compressor.
  - b. Open the gas charge valve very slowly. Allow helium gas to escape until pressure gauge reads 50-100 psig (345-690 kPa).
  - c. Close the gas charge valve and reinstall the charging line to the gas charge fitting, refer to step 4 for procedure.
4. If the pressure is low, attach a helium bottle, regulator, and charging line to the compressor and perform the following:
  - a. Remove the flare cap of the gas charge fitting on the rear of the compressor.
  - b. Loosely attach a charging line from the helium pressure regulator on the helium bottle to the 1/4-inch male flare fitting installed on the helium charge fitting of the compressor.

**NOTE:** Use only 99.999% pure helium.

- c. Set the helium pressure regulator to 10 to 25 psig (70-125 kPa). Allow helium gas to flow through the charging line

and around the loosened flare fitting for 30 seconds to purge the charging line of air. Then tighten the flare nut at the end of the charge line.

- d. Slowly add helium gas until compressor pressure gauge reads 195-205 psig (1345-1415 kPa).
5. Turn on the system power ON/OFF switch.
6. Note helium pressure gauge reading immediately after startup. It should read 50-100 psig (345-690 kPa). If necessary add additional helium gas by slowly opening the helium charge valve on the rear of the compressor until the helium pressure gauge rises to 50-100 psig (345-690 kPa).
7. Allow the cryopump to operate until a cooldown temperature of 20K or less is reached.

Adjust the helium pressure if necessary as described in step 6 until the helium pressure gauge reads 80-100 psig (550-690 kPa) while the system is operating.

8. Allow the system to reach steady state. Recheck the helium pressure.
9. When steady state is achieved, shut the system off and allow the system time to reach steady state conditions at room temperature.
10. When the system reaches room temperature, the pressure reading on the compressor gauge is the system charge pressure.

**NOTE:** Record the compressor static pressure in your operating log. This is the static pressure for your particular installation and should be used for checking compressor performance or when troubleshooting the installation.

11. Ensure that the helium charge valve on the compressor is tightly closed. Then shut off the helium pressure regulator or the helium bottle. Remove the charging line from the male flare fitting and reinstall the flare cap.

*This Page Intentionally Left Blank*